

Matrix Electronic Co.,Ltd

Company Profile



Our Mission

Quality Excellent Quality Control to ensure product quality

Delivery..... Mass Production experience over 20 years in the field

Cost.....Cost competition in market

Service.....Satisfied Sales service

Technology...Outstanding R&D experience and Innovative Support



漢士電子有限公司
Matrix Electronics Co.,Ltd

About Matrix

Funded

Sep, Y2000

Headquarter

Taoyuan, Taiwan

Chairman

Richard Hsieh

Capital

US\$6.8M

Sales Revenue

US\$74.6M(~Y2022)

Products

- **Magnetic Components**
LAN XFMERs/Power Inductor, Powe XFMERs, Common Chock
- **Mechanical Components**
USB/HDMI/DDR/NGFF/RJ45 ICMs/SIM&SD Card/FPC/SAS PCI-e/ SATA/
D-Sub/Mini PCI Connectors
- **Cable Assembly Parts**
NB Pad Accessory(USB-LAN, HDMI-VGA Adapters)
Wire Harness & Cables
- **Customized Parts**
Shield/Die Casting Parts

Plant/Factory

China(Guangdong/Sichuan)/Thailand





漢士電子有限公司
Matrix Electronics Co.,Ltd

Background

**Guangdong Factory
Established(Chang-An)**

**Guangdong Factory
Established(Chang-Ping)**

**SiChuan Factory
Established(De-Yang)**

**Taiwan Headquarter
Established(Tao-yuan)**

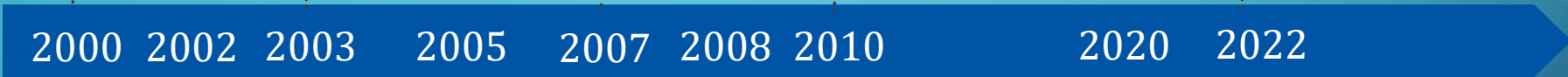

QC8000 certification

ISO 9001:2000 certification

IATF16949 certification



**Invested Wan Ming Co., Ltd
(plating factory)**

ISO 14001:2004 certification

**Thailand Factory
Established(Bangkok)**



QC 080000 IECQ HSPM



漢士電子有限公司
Matrix Electronics Co.,Ltd

Location

Taiwan HQ-
Sales/Engineer/Quality/HR/
Financial

Dongguan-
Plant/Sales/Engineer

Sichuan-
Plant

Thailand-
Plant

Japan-Sales Team

Korea-Sales Distributor

Germany-Sales Distributor

USA-Sales Team





Sales Revenue

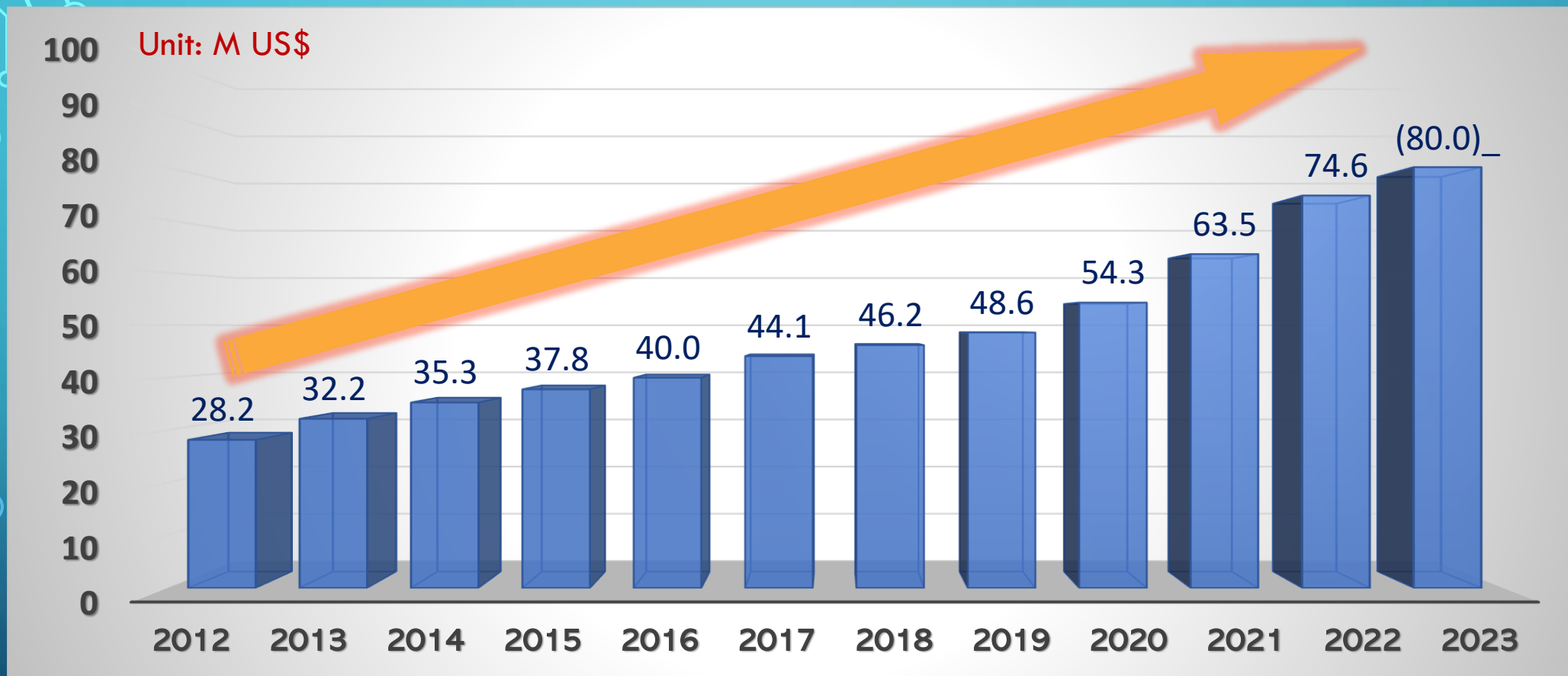

CAGR(Compound annual growth rate) 10.2%



Sales Revenue By Region & Product

REGION SELLING RATE %

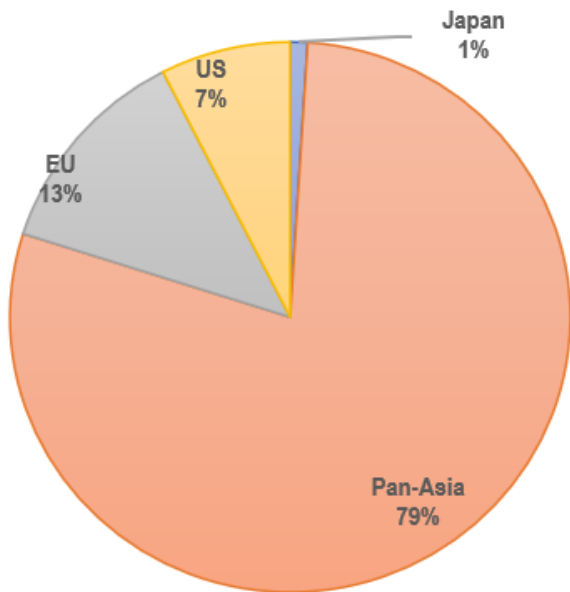

PRODUCT SELLING RATE %

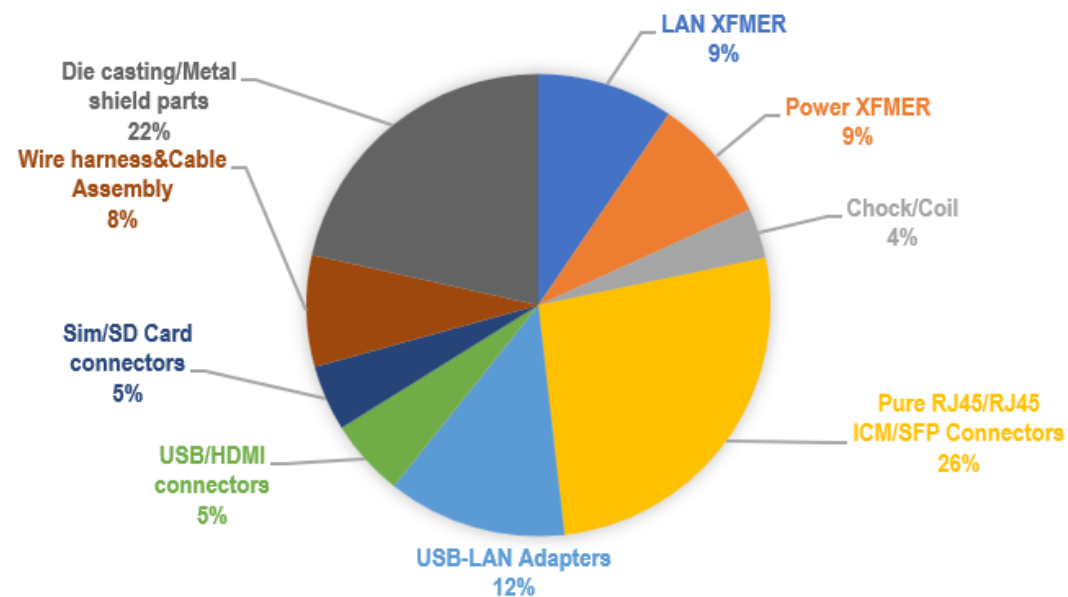

M US\$

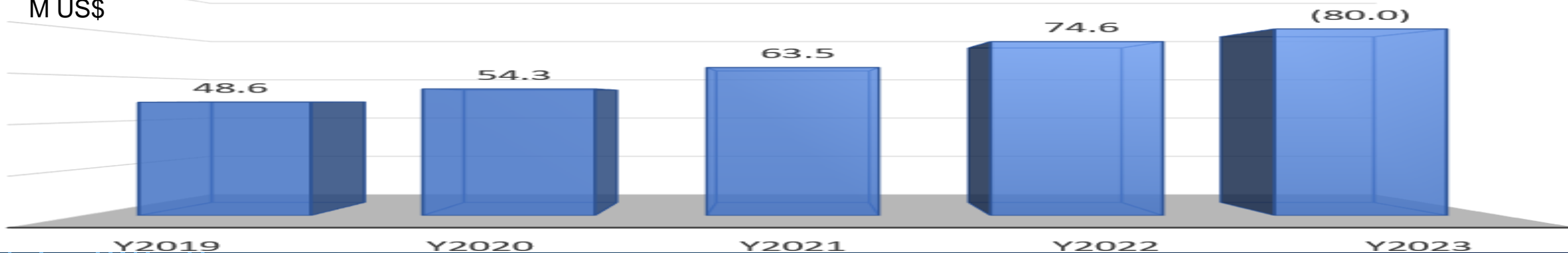



Product Instruction

Magnetic Components

Mechanical Components

Cable Assembly Parts

Customized Parts

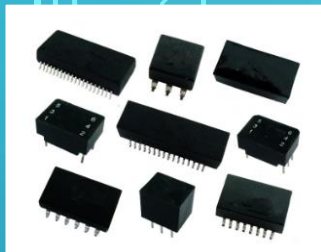

LAN XFMERs



Power/Telecom XFMERs



RJ45 Pure/ICMs

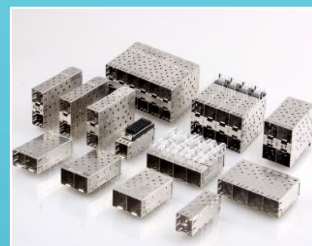

SFP Cage/Connector



USB-LAN VGA-HDMI Hub



Die Casting

Vehicles

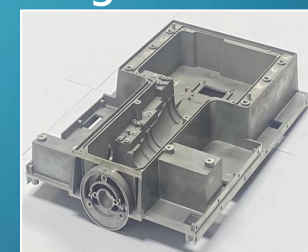

Optical



Common Chock & Inductors



Coils



USB Connector



Sim/SD card connector

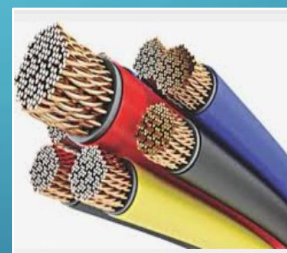

Wire harness



Networking



Consumer



HDMI connector



FPC/M.2/SATA/B-B connector



IOT



Shield/CNC Part



Magnetic Components

-LAN XFMERS- Single/Dual/Quad Port

DIP Type



SMT Type



Speed (Base-T)	DIP			SMT		
	1port	2port	4port	1port	2port	4port
10/100	⊙	⊙		⊙	⊙	⊙
1G	⊙	⊙	⊙	⊙	⊙	
2.5G	⊙	⊙	⊙	⊙	⊙	
5G	⊙	⊙	⊙	⊙	⊙	
10G				⊙		
18G 				⊙		

PoE: 15W-90W

Hi-pot: 1.5KVA-4KVA



<Features>

- ✓ Footprint compatible with most standards
- ✓ PoE models available
- ✓ RoHS and Pb-Free Compliant



漢士電子有限公司
Matrix Electronics Co.,Ltd

Magnetic Components

-Power XFMRs/Coils/Inductors



DLAN Series

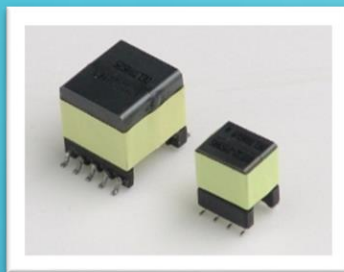

DEP Series



ERL Series



ET Series



EE Series

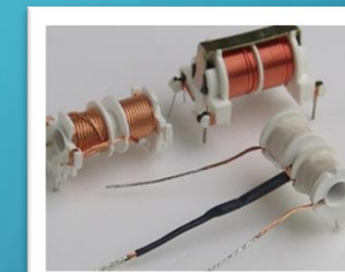

DY Series



DCDR series



DLCH Series



DCD Series



DWCI Series

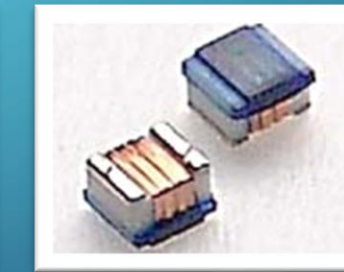

DHCI Series



DLC Series



Mechanical Components

-RJ45 Pure/Integrated Modular Connectors



G7 RJ45 1x1 R/A



G8 RJ45 1x1 R/A LowProfile



G9 RJ45 1x1 R/A SMT 100M

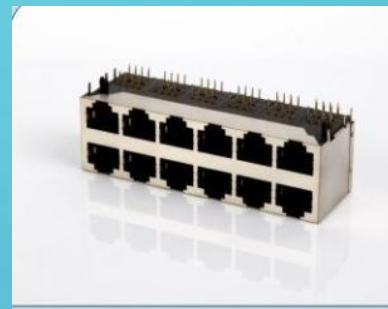

G1 RJ45 2x6 Series

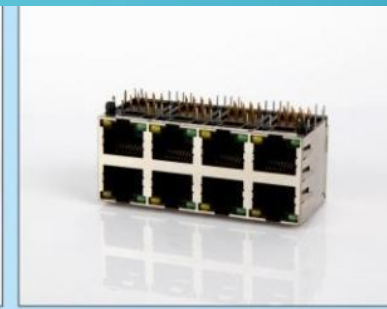

G2 RJ45 2x4 +LED



G3 RJ45 2x3 +LED R/A



G10 RJ45+Duble USB R/A



G11 RJ11 2x1 R/A



G12 RJ45 1x1 R/A



G4 RJ45 1x5 180度



G5 RJ45 2x2



G6 RJ45 1x2 +LED R/A

RJ45 Integrated Modular
Speed: 10/100/1000/2.5G/5G/10G Baset-T
Type: Right Ange/Vertical/Slim



<Features>

- ✓ Footprint compatible with most standards
- ✓ PoE models available
- ✓ RoHS and Pb-Free Compliant



Mechanical Components

-SFP Connectors

1XN (Cage & Connector)

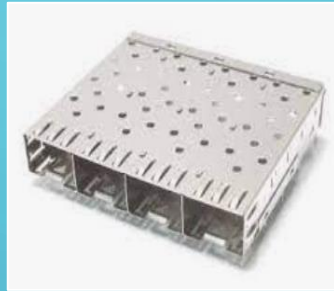

Series	Speed	Conector	Cage
SFP	1G	v	v
SFP+	10G	v	v
SFP28	25G	v	v
QSFP28	100G	v	v
QSFP112	400G	v	v

2XN

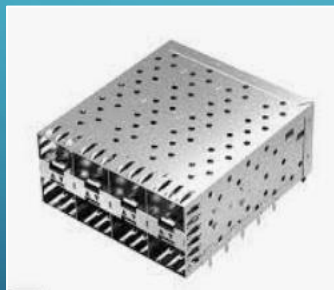

Transmission: NRZ/PAM4
 Shield leg: DIP/Press fit
 Speed: 1G/10G/25G/100G/400G
 Option: Heat Sink/Light Pie



Mechanical Components

-USB Connectors

		Type-A	Type-B	Type-C	Mini-A	Mini-B	Mini-AB	Micro-B	Micro-AB
USB2.0		 Type-A	 Type-B	-	 Mini-A	 Mini-B	 Mini-AB	 Micro-B	 Micro-AB
USB3.2		 Type-A SuperSpeed	 Type-B SuperSpeed	 Type-C	-	-	-	 Micro-B SuperSpeed	-



B1 USB A Type Female Solder



B2 USB A Type Female R/A



B3 USB A Type Female Short R/A

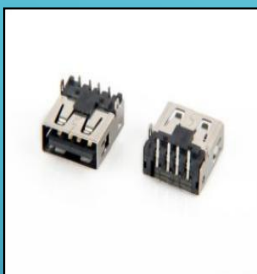

B7 USB B Type Female SMT



B8 USB A Type Female R/A



B9 Mini USB 5P B Type Female SMT

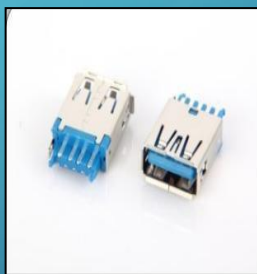

A1 USB3.0 A Type Female Solder



A2 USB3.0 A Type Male Solder



A3 USB3.0 A Type Male SMT



B4 USB A Type Female SMT



B5 USB A Type Female R/A



B6 USB A Type Female R/A

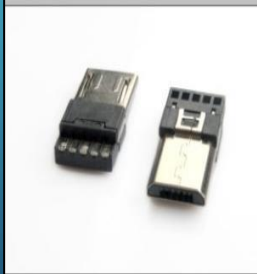

B10 Micro USB 5P B Type Male Solder



B11 Micro usb 5P B Type Female SMT Shell DIP



B12 Micro usb 5P B Type Female SMT Shell SMT

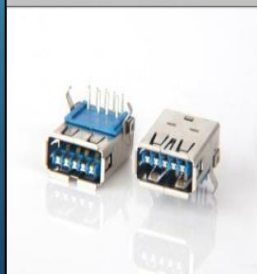

A4 USB3.0 A Type Female R/A



A5 USB3.0 A Type Female D/P



A6 USB3.0 A Type Female R/A



Mechanical Components

-SIM/SD Card Connectors

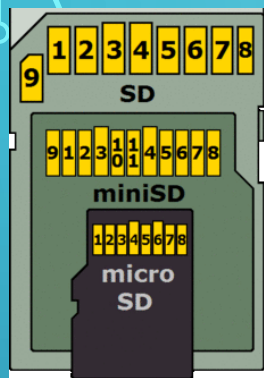

Micro-SD



Micro-SD TF



Standard SD

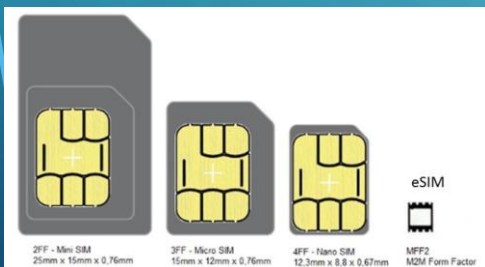

Nano SIM



Micro SIM



Mini SIM



Mechanical Components -HDMI Connectors



HDMI A Type



HDMI C Type(Mini)



HDMI D Type(Micro)



D7 HDMI 19P Female SMT
CL=2.21(forward)



D8 HDMI 19P Female DIP
CL=2.4(forward)



D9 HDMI 19P Female C Type SMT



D1 HDMI 19P A Type Female
Standard SMT



D2 HDMI 19P A Type Female
H=8.0 SMT



D3 HDMI 19P Female Vertical SMT



D10 HDMI 19P A Type Male Solder



D11 HDMI 19P D Type Male Solder



D12 HDMI 19P D Type Female SMT



D4 HDMI 19P Female DIP
CL=1.65(forward)



D5 HDMI 19P Female DIP
CL=1.95 (forward)



D6 HDMI 19P Female DIP
CL=0.4 (reverse)



Mechanical Components

-M.2/SATA/ESATA/FPC/B-B Connectors



M.2(B-Key)

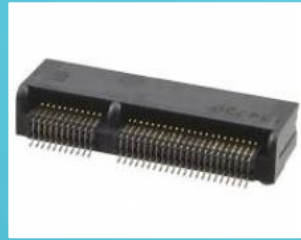

M.2(E-Key)



SATA 7+6P



SATA 7+15P

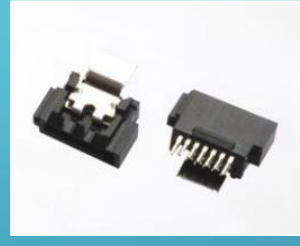

SATA 7P



FPC



Board-Board





Mechanical Components

-D-Sub Connectors



H1 D-SUB 8W8 Female Type



H2 D-SUB 3W3 Male Female Solder Type



H3 D-SUB 5W5 Female /Male Solder Type



H4 D-SUB 7W2 Male Solder Type



H5 D-SUB 13W3 Female R/A DIP Same Axle



H6 D-SUB 13W3 Female /Male R/A STD Type



Cable Assembly Parts

-Wire Harness & USB Adaptor

Outside



HDMI



Micro USB-USB



Mimi USB-USB



USB LAN Adapter



AV Adapter

Inside





漢士電子有限公司
Matrix Electronics Co.,Ltd

Vehicles application



Customized Parts

-Die Casting Solutions



... TESLA



... FORD/TOYOTA



... BMW/Audi



... BYD



漢士電子有限公司
Matrix Electronics Co.,Ltd

Networking Products



Customized Parts -Die Casting Solutions

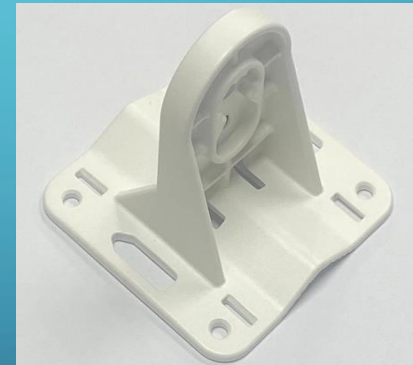
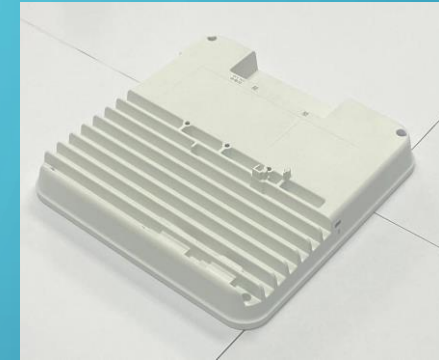



漢士電子有限公司
Matrix Electronics Co.,Ltd

Customized Parts

-Die Casting Solutions

IOT Products

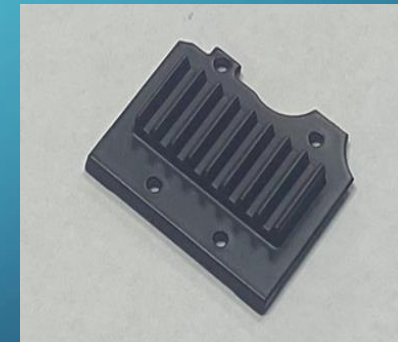
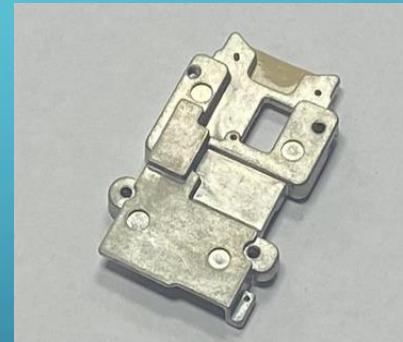
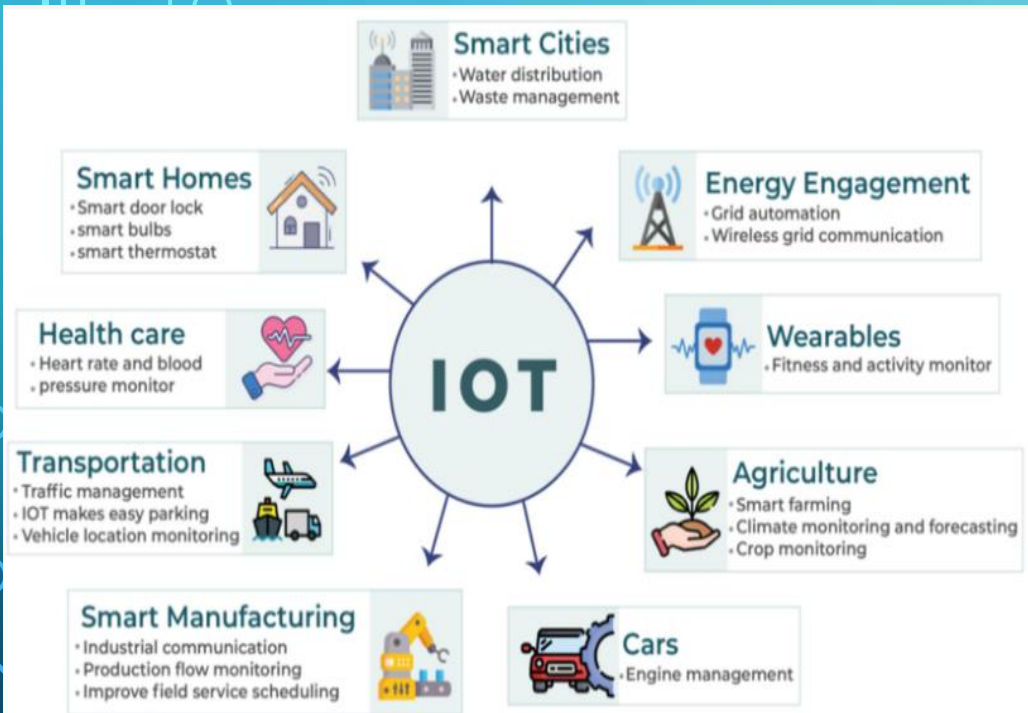



漢士電子有限公司
Matrix Electronics Co.,Ltd

Optical Products



Customized Parts

-Die Casting Solutions

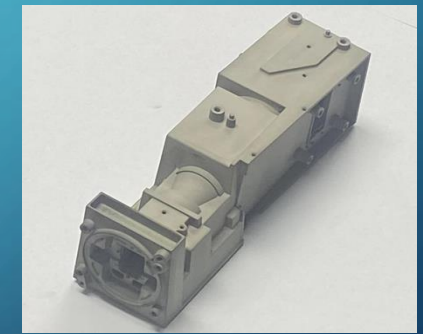
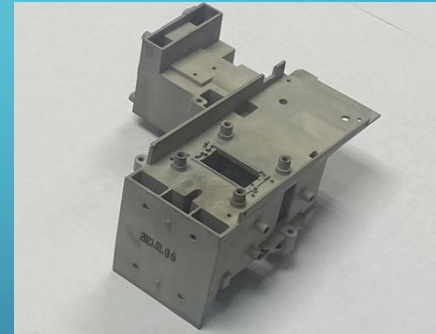
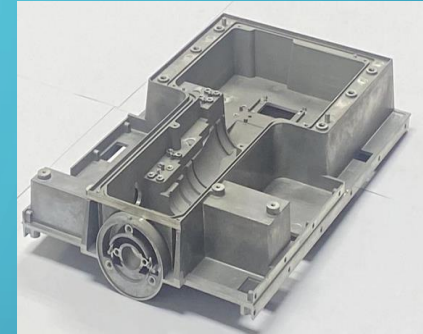



漢士電子有限公司
Matrix Electronics Co.,Ltd

Customized Parts

-Die Casting Solutions

Consumer Products

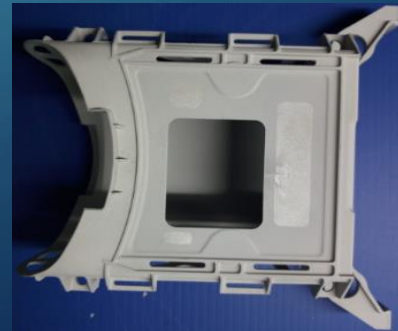
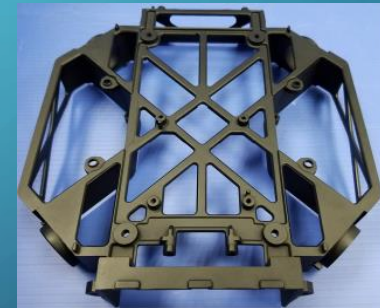



漢士電子有限公司
Matrix Electronics Co.,Ltd

Customized Parts

-Die Casting Solutions

Consumer Products

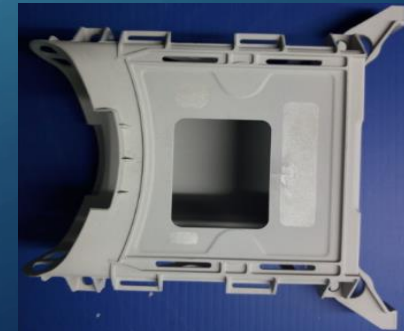
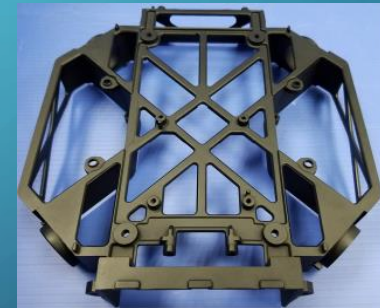



漢士電子有限公司
Matrix Electronics Co.,Ltd

Customized Parts

-Stamping & CNC Parts

Stamping Parts

CNC Parts





漢士電子有限公司
Matrix Electronics Co.,Ltd

Production Line -Equipment & Line

Injection Machine



CNC Machine



PG Machine



Stamping Machine



Die Casting Machine



Auto Winding Machine



EDM Machine



FCC ASSY Machine



Terminal ASSY Machine



Laser Printing Machine





漢士電子有限公司
Matrix Electronics Co.,Ltd

Production Line

-Quality Management

□ Mechanical

- ✓ Vibration
- ✓ Force analysis
- ✓ Durability

□ Electrical

- ✓ Contac resistance
- ✓ Insulation resistance
- ✓ High voltage
- ✓ High frequency



□ Environmental

- ✓ Thermal shock
- ✓ Salt spray
- ✓ Temperature & Humidity
- ✓ Steam aging

□ Process

- ✓ Simulation
- ✓ SMT Simulation
- ✓ Soldering ability





Production Line

-Technical Management

▣ Static Test Item (Component Test)

- LCR test
- Insertion Loss test
- Return Loss test
- Cross Talk test
- Mode Rejection/Conversion test
- HI-POT test

▣ Dynamic Test Item (System Test)

High Frequency

- ◆ IEEE Waveform test
- ◆ IEEE Return loss test
- ◆ IEEE BER/Copy files test

Electrical Compatibility

- ◆ EMI test
- ◆ ESD test
- ◆ ISN test
- ◆ Surge test





漢士電子有限公司
Matrix Electronics Co.,Ltd

Value Partners





漢士電子有限公司
Matrix Electronics Co.,Ltd

Thank You



Matrix Electronics Co., Ltd

No. 89, Shouchang St., Taoyuan Dist., Taoyuan City , 330038 , Taiwan

Tel: 886-3-2289050

